

# Project 3

---

## Angle Clamp Assembly

In this project, you will create components for a Angle Clamp assembly and then assemble them. You need to create all the components as separate part files. The views and dimensions of the components are shown in Figures P3-3 through P3-13.

You can also download the model files for your reference from [www.cadcim.com](http://www.cadcim.com). To download the files, use the following path: *Textbooks > CAD/CAM > SOLIDWORKS > SOLIDWORKS 2021 for Designers > Projects for Free Download > Project 3*

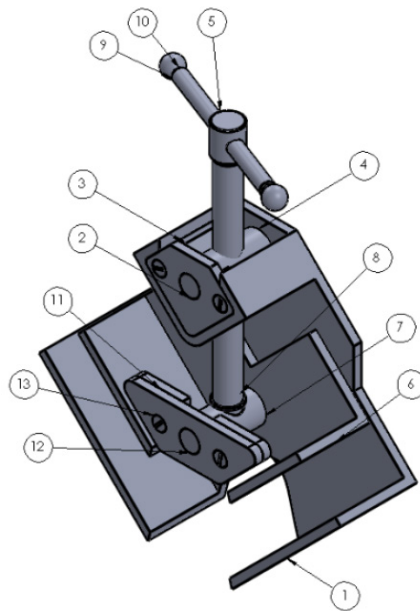

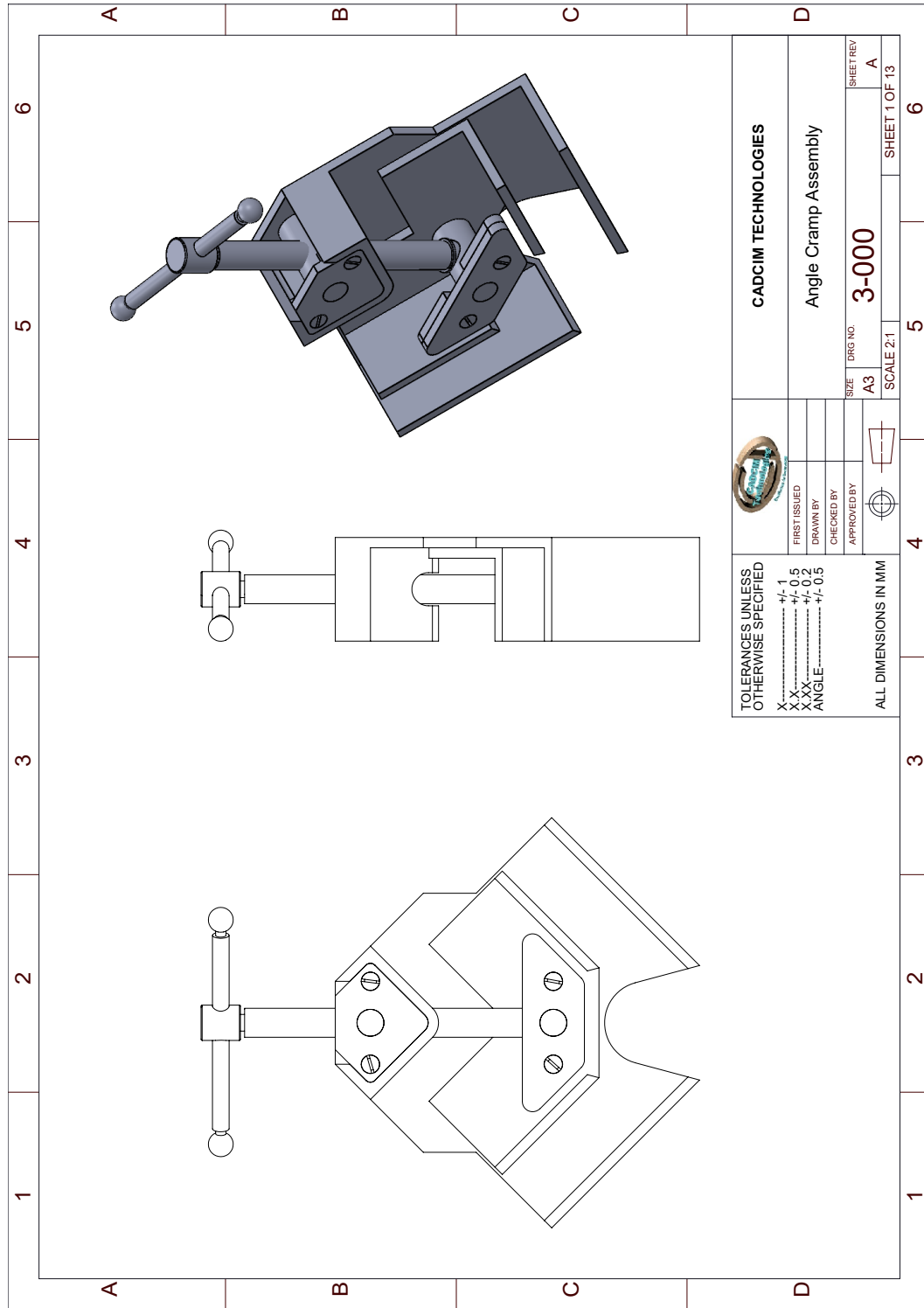
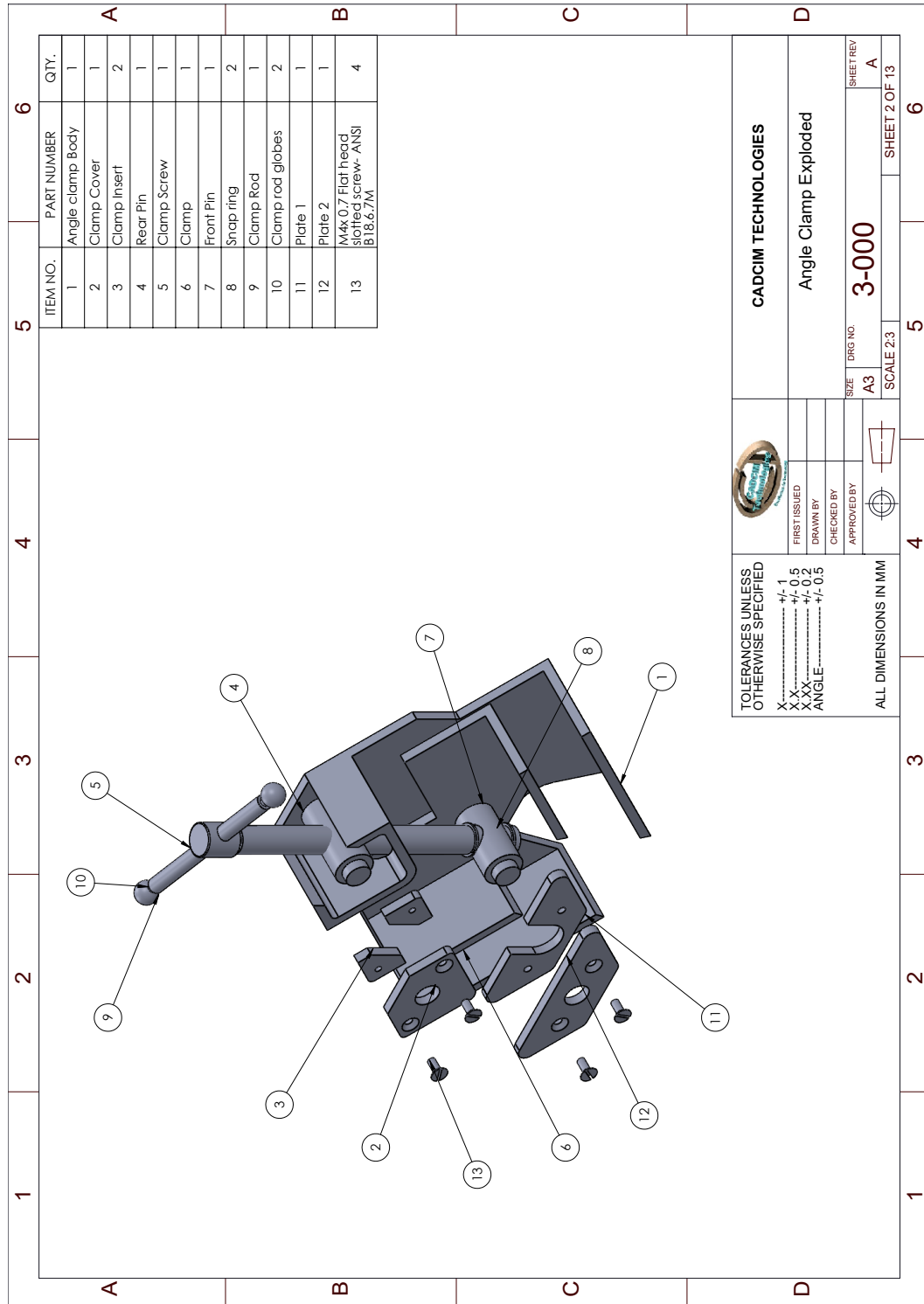

Figure P3-1 The Angle Cramp assembly



		<b>CAD/CIM TECHNOLOGIES</b>	
TOLERANCES UNLESS OTHERWISE SPECIFIED X..... +/- 1 XX..... +/- 0.5 XXX..... +/- 0.2 ANGLE..... +/- 0.3		Angle Clamp Exploded	
FIRST ISSUED DRAWN BY CHECKED BY APPROVED BY	DRG NO. SCALE 2:3 SHEET 2 OF 13	SIZE A3	SHEET REVISION 3-000 A
ALL DIMENSIONS IN MM		SCALE 2:3	

Figure P3-2 The exploded view of Angle Clamp assembly

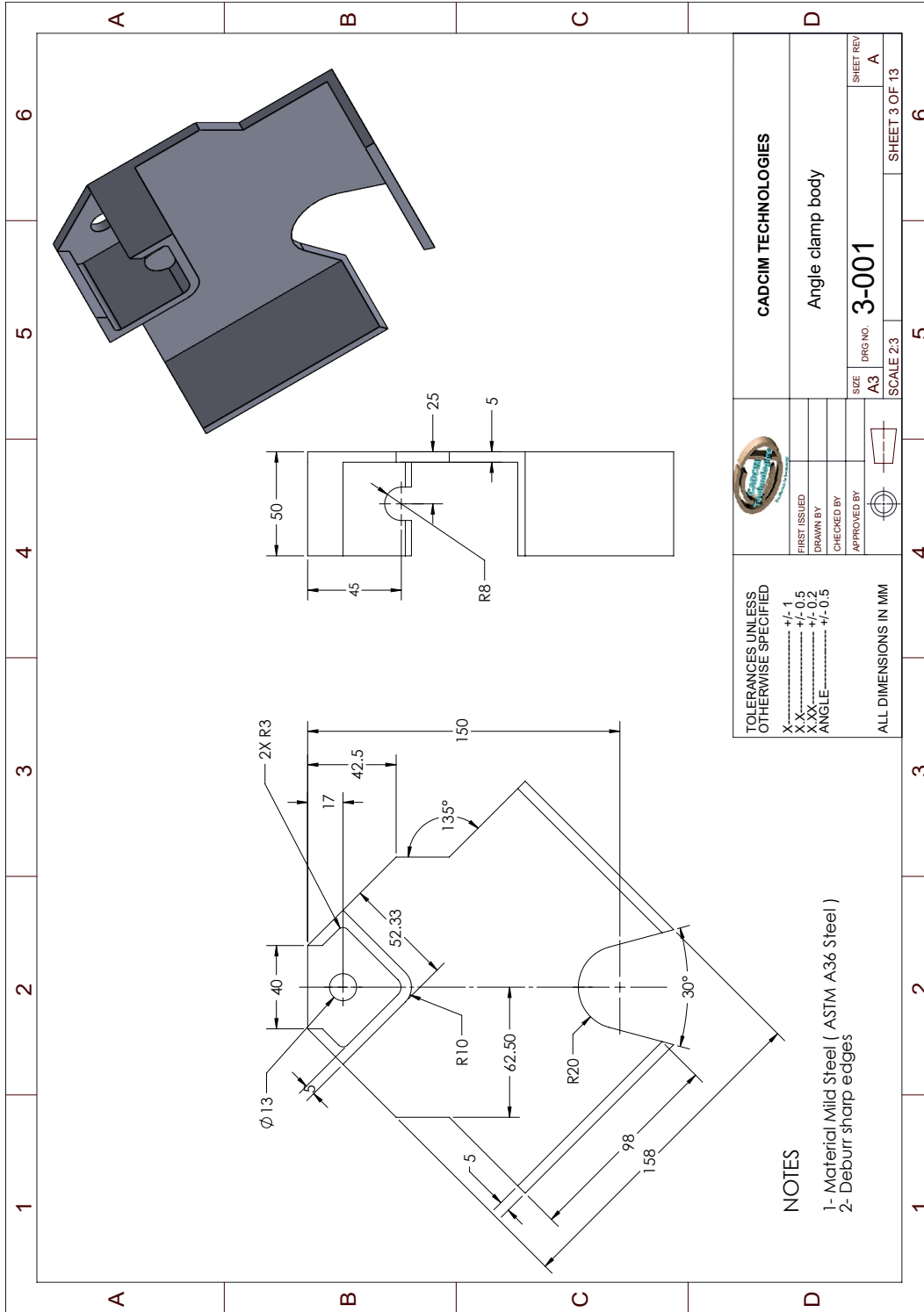

Figure P3-3 Views and dimensions of Angle Clamp Body

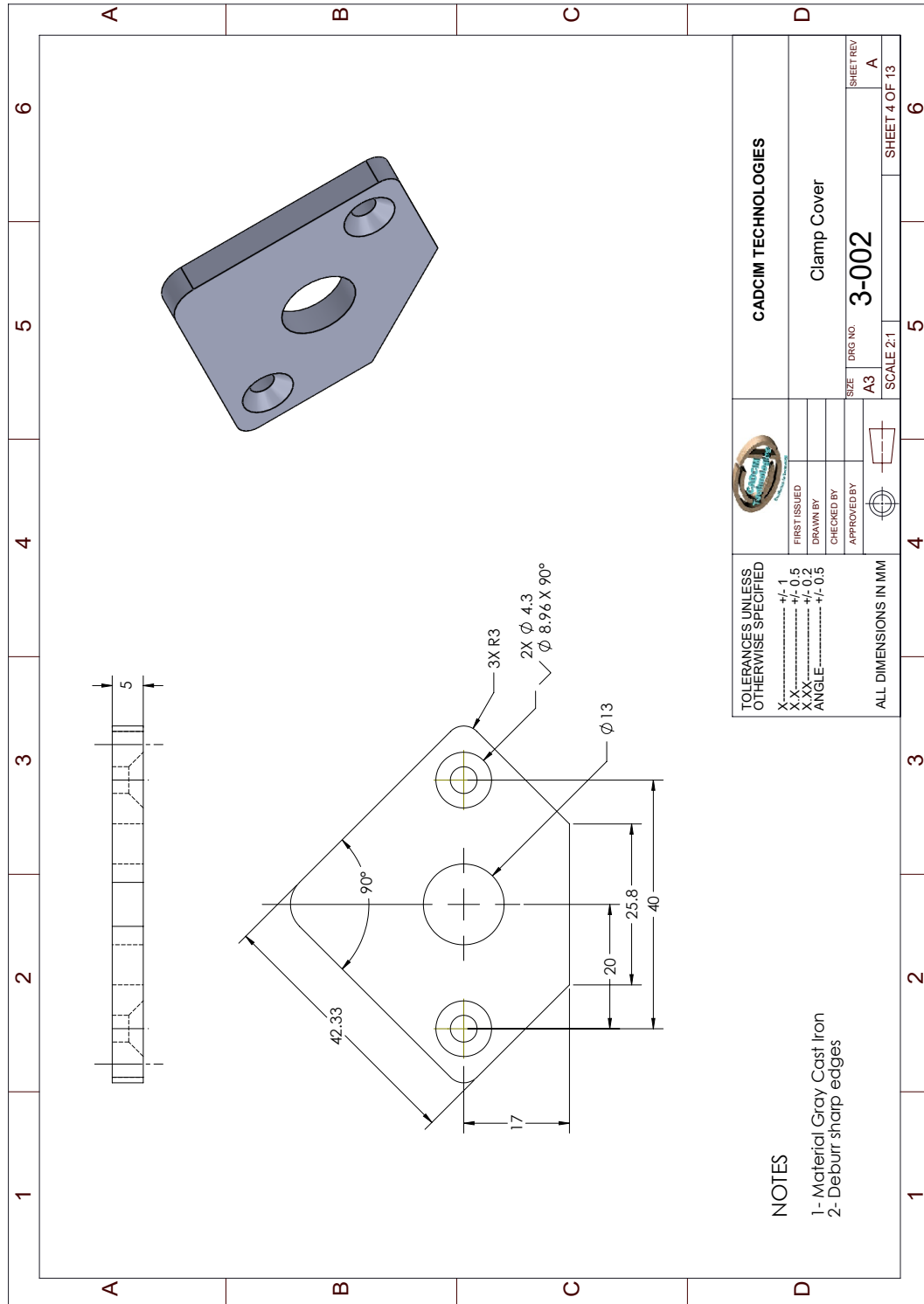

Figure P3-4 Views and dimensions of Clamp Cover

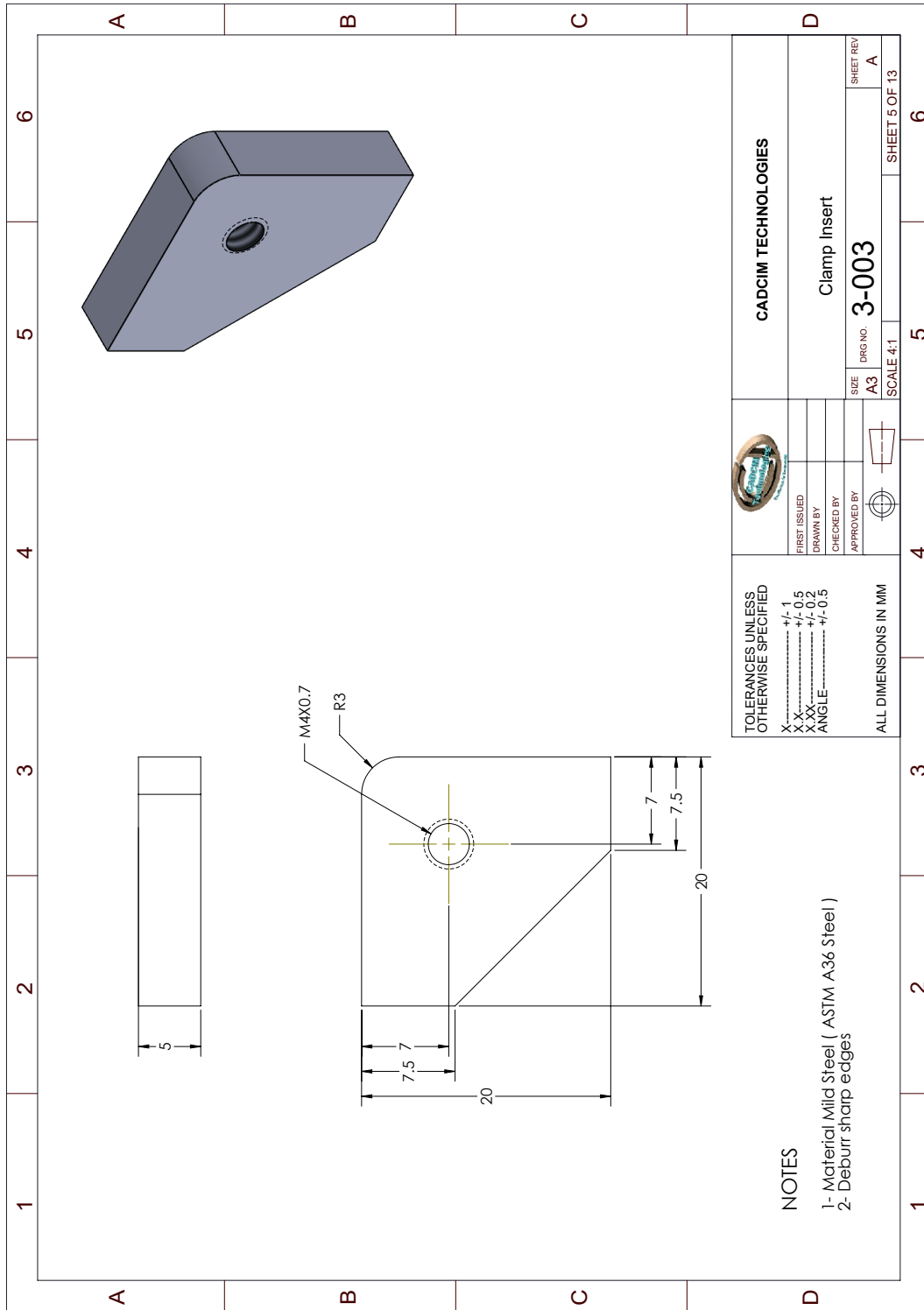

Figure P3-5 Views and dimensions of Clamp Insert

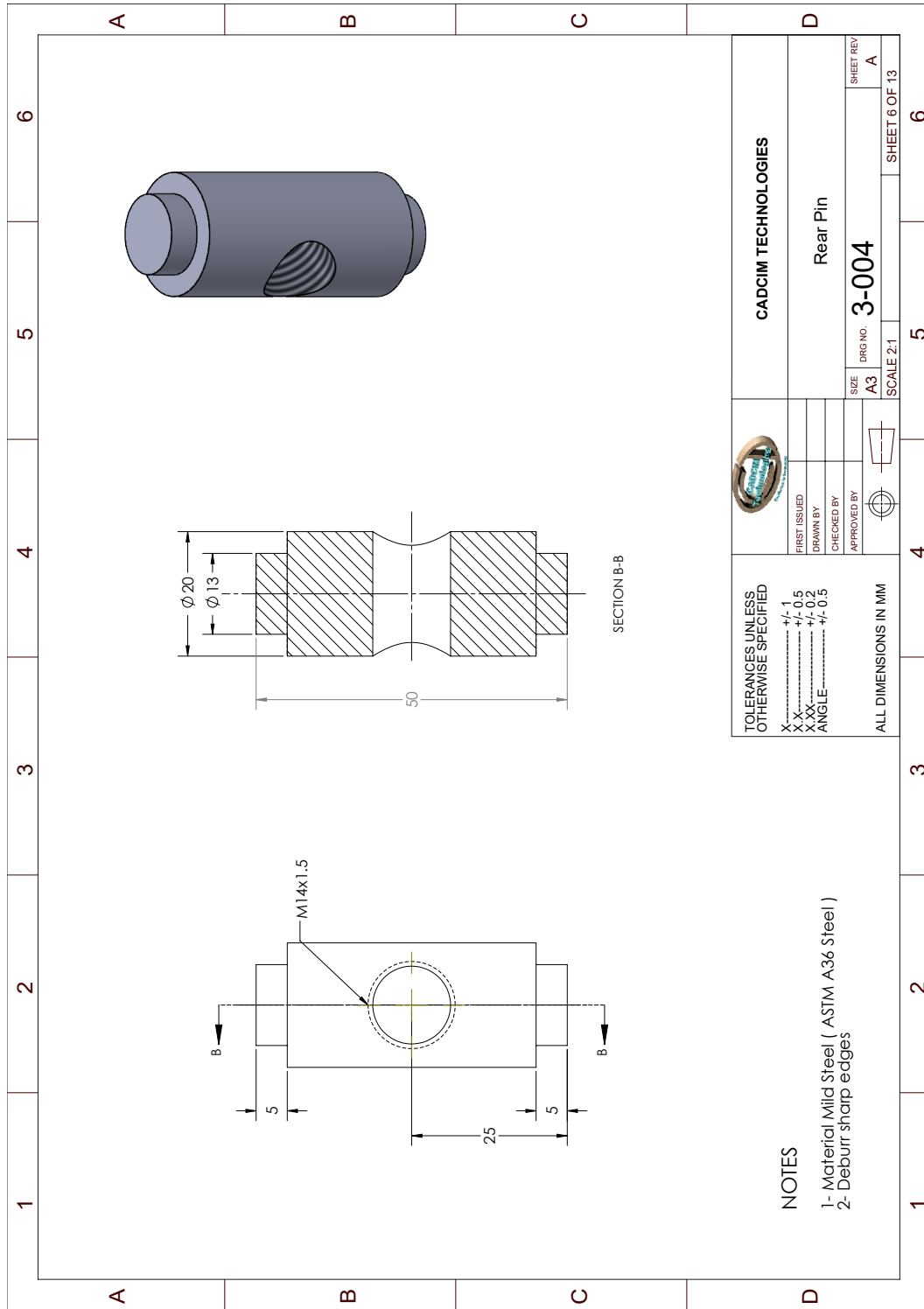

Figure P3-6 Views and dimensions of Rear Pin

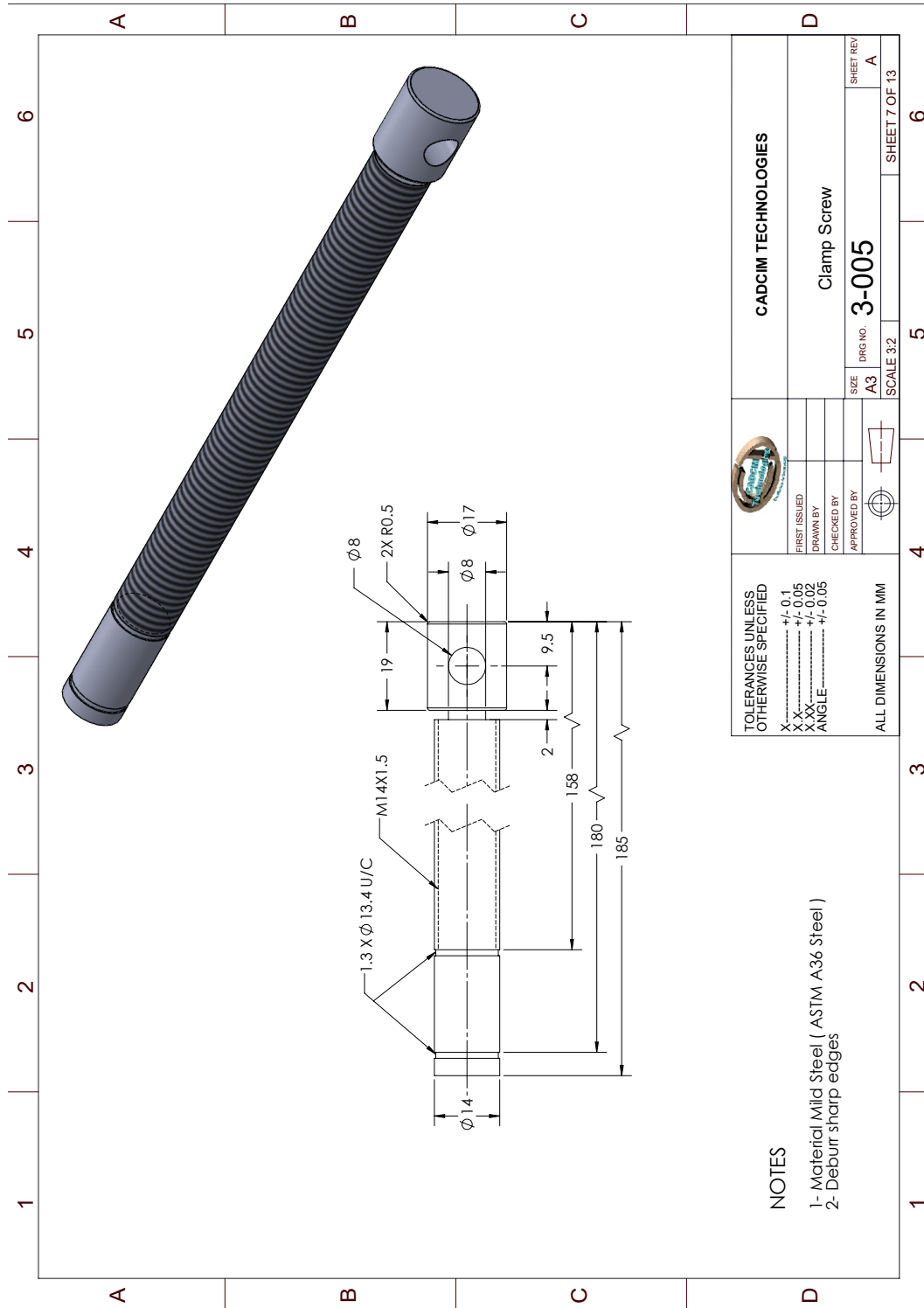

Figure P3-7 Views and dimensions of Clamp Screw



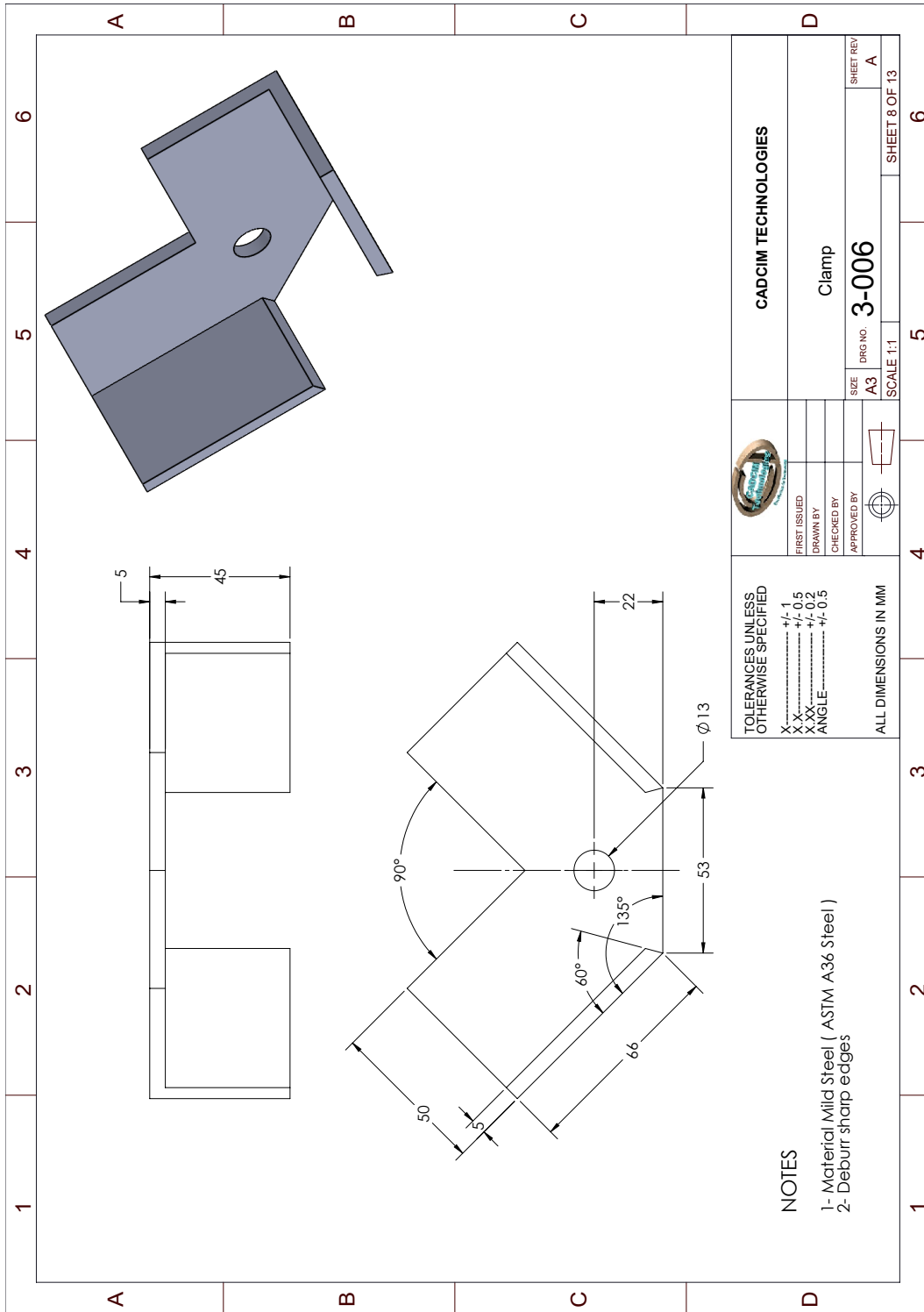

Figure P3-8 Views and dimensions of Clamp

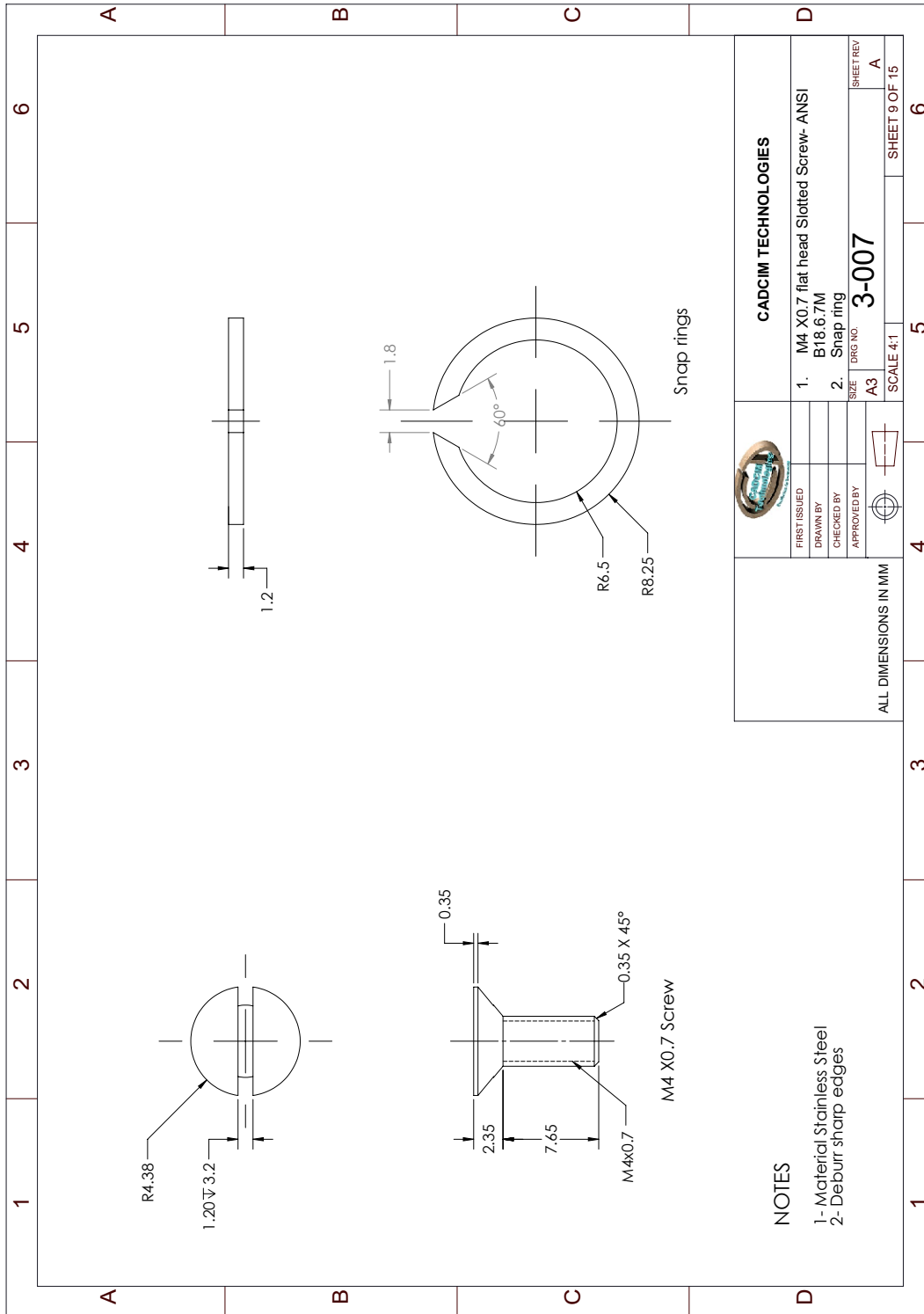

Figure P3-9 Views and dimensions of M4 X 0.7 flat head slotted screw

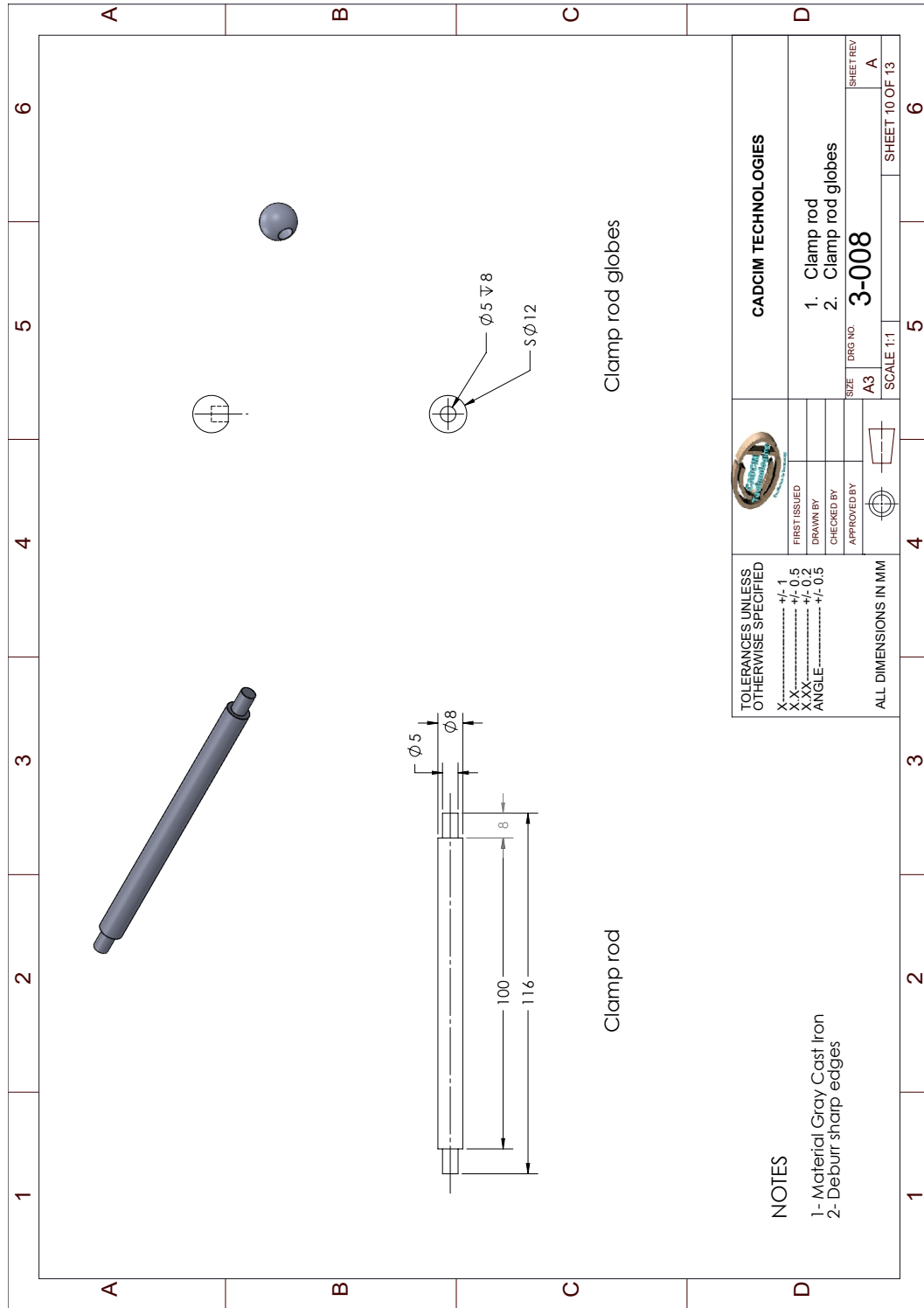

Figure P3-10 Views and dimensions of Clamp Rod and Clamp Rod Globes

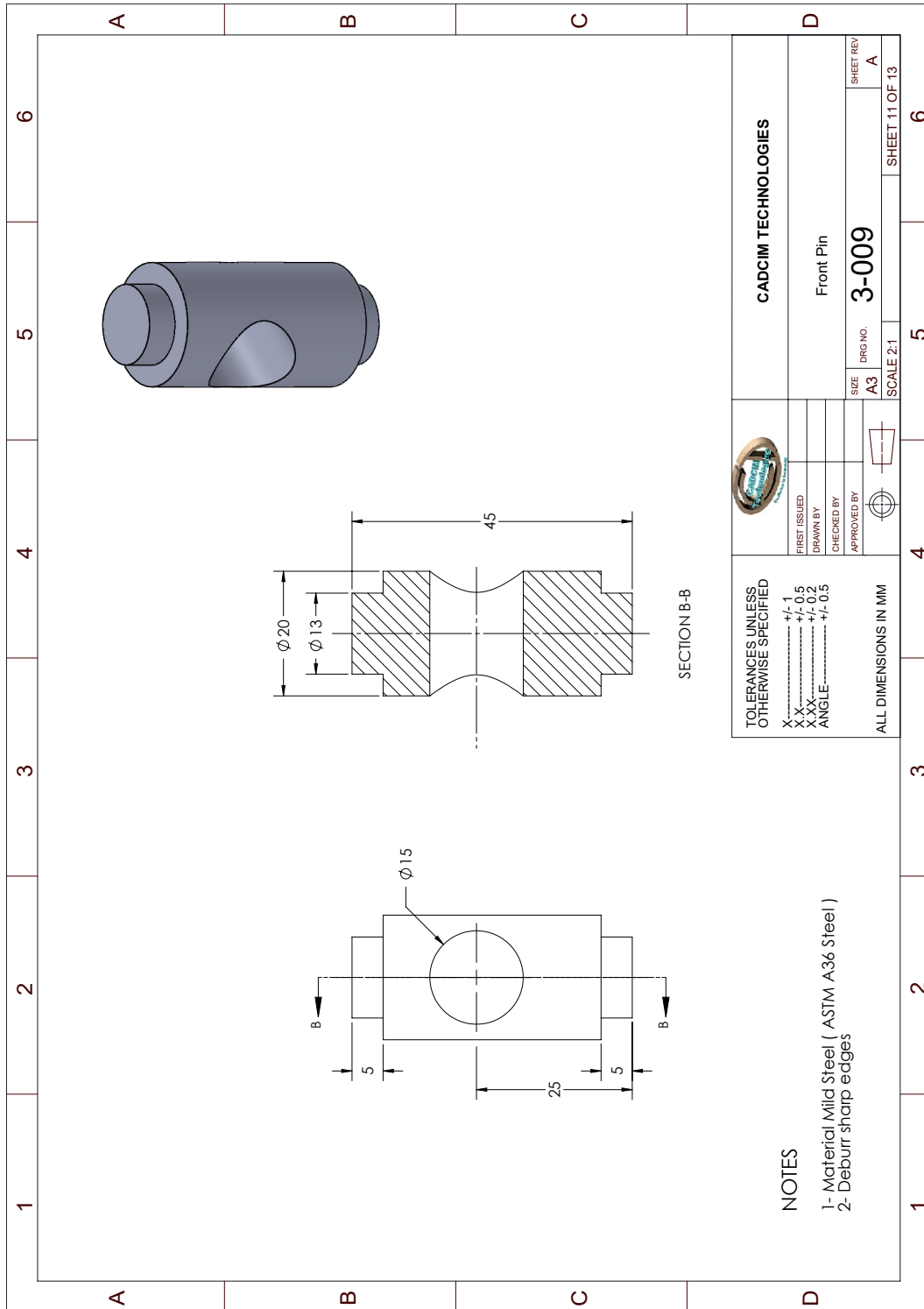

Figure P3-11 Views and dimensions of Front Pin

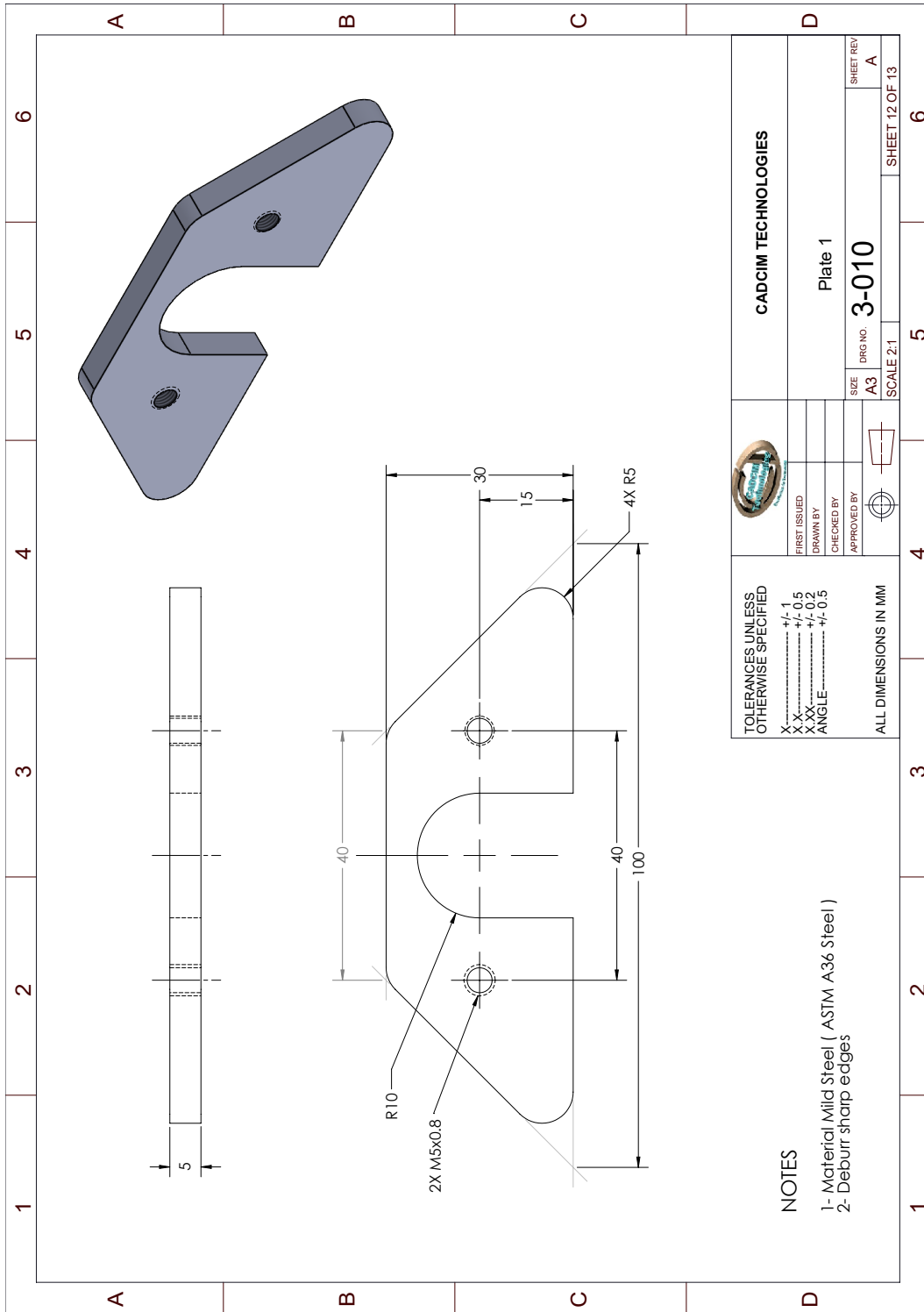

Figure P3-12 Views and dimensions of Plate 1

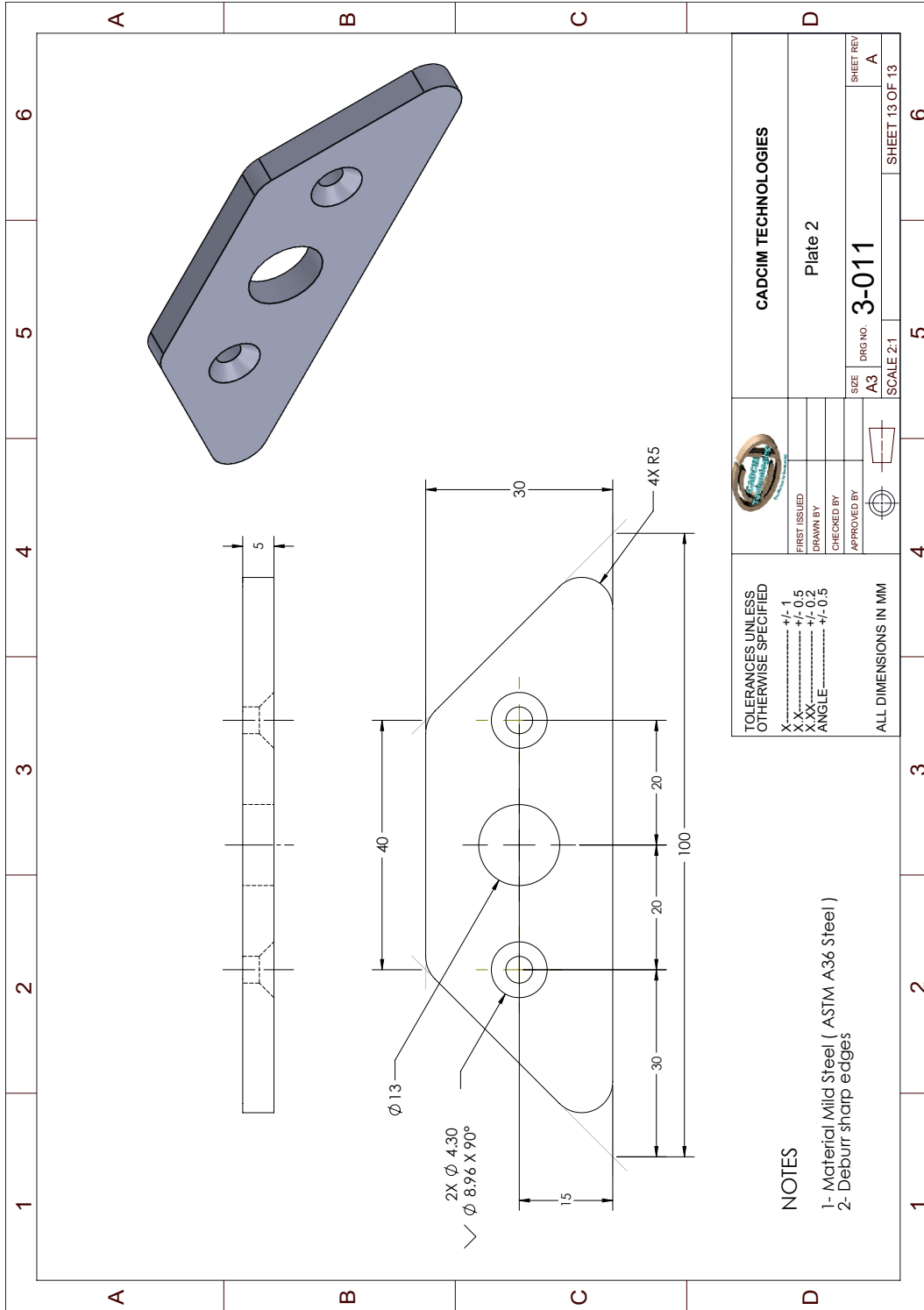

Figure P3-13 Views and dimensions of Plate 2